

Length, Area and Volume

by Stephen New

Length

1. Definition: The **length** of the line segment on the real line \mathbf{R} from x_1 to x_2 is equal to $l = |x_2 - x_1| = \sqrt{(x_2 - x_1)^2}$. The **length** of the line segment in the Euclidean plane \mathbf{R}^2 from the point (x_1, y_1) to the point (x_2, y_2) is equal to $l = \sqrt{(x_2 - x_1)^2 + (y_2 - y_1)^2}$. The **length** of the line segment in Euclidean space \mathbf{R}^3 from the point (x_1, y_1, z_1) to the point (x_2, y_2, z_2) is equal to $l = \sqrt{(x_2 - x_1)^2 + (y_2 - y_1)^2 + (z_2 - z_1)^2}$.

2. Note: Given a (reasonably well-behaved) curve in \mathbf{R}^2 or \mathbf{R}^3 , we can approximate its length by choosing many points along the curve and finding the sum of the lengths of the line segments between these points. We can find the exact length of the curve by finding the limit of these approximate lengths as the size of the small line segments tends to zero.

3. Example: Approximate the length of the parabola $y = x^2$ from the point $(0, 0)$ to the point $(1, 1)$ by choosing 6 points along the curve and finding the sum of the lengths of the 5 line segments between these 6 points.

Solution: We choose the 6 points $(x_k, y_k) = \left(\frac{k}{5}, \frac{k^2}{25}\right)$ with $k = 0, 1, 2, 3, 4, 5$. Note that $(x_0, y_0) = (0, 0)$ and $(x_5, y_5) = (1, 1)$. For $k = 1, 2, 3, 4, 5$, the length of the k^{th} line segment (that is the segment from (x_{k-1}, y_{k-1}) to (x_k, y_k)) is equal to

$$\begin{aligned} l_k &= \sqrt{(x_k - x_{k-1})^2 + (y_k - y_{k-1})^2} \\ &= \sqrt{\left(\frac{k}{5} - \frac{k-1}{5}\right)^2 + \left(\frac{k^2}{25} - \frac{(k-1)^2}{25}\right)^2} \\ &= \sqrt{\left(\frac{1}{5}\right)^2 + \left(\frac{2k-1}{25}\right)^2} \\ &= \frac{1}{25} \sqrt{4k^2 - 4k + 26}. \end{aligned}$$

The total length is equal to

$$\begin{aligned} l &\cong l_1 + l_2 + l_3 + l_4 + l_5 \\ &= \frac{1}{25} (\sqrt{26} + \sqrt{34} + \sqrt{50} + \sqrt{74} + \sqrt{106}) \\ &\cong 1.476. \end{aligned}$$

We remark that it can be shown, using the methods of first-year university calculus, that the exact length of the parabola $y = x^2$ from $(0, 0)$ to $(1, 1)$ is equal to

$$l = \frac{\sqrt{5}}{2} + \frac{1}{4} \ln(2 + \sqrt{5}) \cong 1.479.$$

4. **Definition:** The **angle** (in radians) between two rays emanating from a point is defined to be the length of the portion of the unit circle, centered at the point from which the rays emanate, which lies between the two rays. The number π is defined to be the angle between two rays pointing in opposite directions. Equivalently, π is defined to be one half of the circumference of a unit circle.

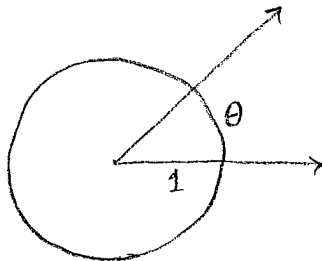

5. **Theorem:** The circumference of a circle of radius r is equal to $l = 2\pi r$. More generally, the length of an arc of a circle of radius r , subtending an angle θ at the center, is equal to $l = r\theta$.

Proof: This follows from the above definition by scaling the unit circle by a factor of r .

6. **Example:** Approximate the value of π by choosing 7 points along the semicircle $y = \sqrt{1 - x^2}$ and finding the sum of the 6 line segments between these points.

Solution: We choose the 7 points $(x_k, y_k) = (\cos \frac{k\pi}{6}, \sin \frac{k\pi}{6})$ with $k = 1, 2, \dots, 6$. To be explicit, we choose

$$(x_0, y_0) = (1, 0), \quad (x_1, y_1) = \left(\frac{\sqrt{3}}{2}, \frac{1}{2}\right), \quad (x_2, y_2) = \left(\frac{1}{2}, \frac{\sqrt{3}}{2}\right), \quad (x_3, y_3) = (0, 1)$$

$$(x_4, y_4) = \left(-\frac{1}{2}, \frac{\sqrt{3}}{2}\right), \quad (x_5, y_5) = \left(-\frac{\sqrt{3}}{2}, \frac{1}{2}\right), \quad (x_6, y_6) = (-1, 0).$$

These 7 points are equally spaced around the semicircle. Each of the 6 line segments between the 7 points subtends an angle of $\frac{\pi}{6}$ at the origin. The length of each segment is

$$l_k = l_1 = \sqrt{(x_1 - x_0)^2 + (y_1 - y_0)^2} = \sqrt{\left(\frac{1}{2}\right)^2 + \left(\frac{\sqrt{3}}{2} - 1\right)^2} = \sqrt{2 - \sqrt{3}}$$

(the length l_k can also be found using the Law of Cosines). The total length of the semicircle is equal to

$$\pi \cong 6l_1 = 6\sqrt{2 - \sqrt{3}} \cong 3.106.$$

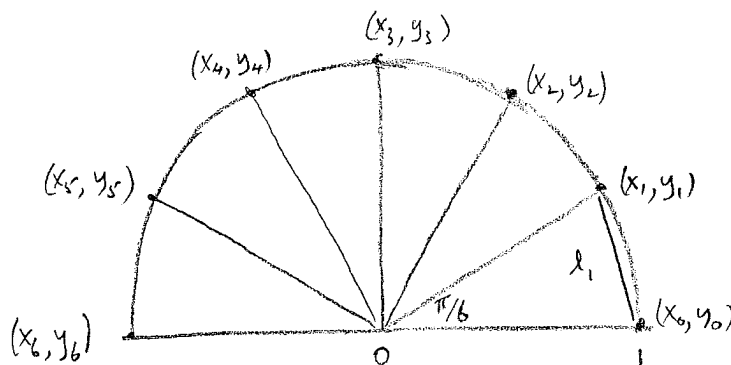

7. Example: Find a sequence of algebraic numbers which become arbitrarily close to π .

Solution: By its definition, π is the length of the semicircle $y = \sqrt{1-x^2}$. For a positive integer n , let $\theta_n = \frac{\pi}{2^n}$. Choose $1+2^n$ points along the semicircle which cut it into 2^n equal arcs, each of length θ_n (and each subtending the angle θ_n at the origin), and let (x_n, y_n) be the point nearest to $(1, 0)$ (in other words let $x_n = \cos \theta_n$ and $y_n = \sin \theta_n$). The arc along the semicircle from $(1, 0)$ to (x_n, y_n) has length θ_n , and this is approximated by the length of the line segment from $(1, 0)$ to (x_n, y_n) , which has length

$$l_n = \sqrt{(x_n - 1)^2 + y_n^2} = \sqrt{x_n^2 - 2x_n + 1 + y_n^2} = \sqrt{2 - 2x_n}$$

since $x_n^2 + y_n^2 = 1$. For large n we have $\pi \cong 2^n l_n = 2^n \sqrt{2 - 2x_n}$.

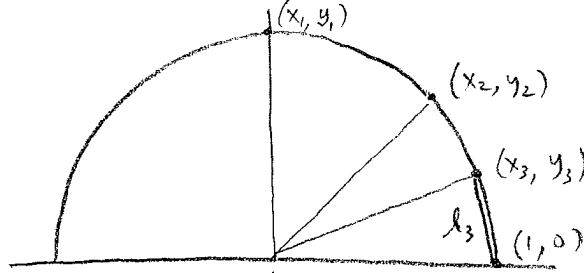

Note that $\theta_1 = \frac{\pi}{2}$ and $(x_1, y_1) = (0, 1)$. Using the half-angle cosine formula, we have

$$x_{n+1} = \cos \theta_{n+1} = \cos \frac{1}{2} \theta_n = \sqrt{\frac{1 + \cos \theta_n}{2}} = \sqrt{\frac{1 + x_n}{2}} = \frac{1}{2} \sqrt{2 + x_n}.$$

Alternatively (for those who do not know the half-angle formula), we can find the value of x_{n+1} in terms of x_n as follows. The midpoint of $(1, 0)$ and (x_n, y_n) is the point $\frac{1}{2}(x_n + 1, y_n)$. Since the point (x_{n+1}, y_{n+1}) bisects the arc from $(1, 0)$ to (x_n, y_n) , it lies along the ray from $(0, 0)$ through the midpoint $\frac{1}{2}(x_n + 1, y_n)$, and so the right-angled triangle with vertices at $(0, 0)$, $\frac{1}{2}(x_n + 1, y_n)$, $(1, 0)$ is congruent to the triangle with vertices at $(0, 0)$, $(x_{n+1}, 0)$ and (x_{n+1}, y_{n+1}) . Thus the distance from $(0, 0)$ to $(x_{n+1}, 0)$ must be equal to the distance from $(0, 0)$ to $\frac{1}{2}(x_n + 1, y_n)$, and so we have

$$x_{n+1} = \frac{1}{2} \sqrt{(x_n + 1)^2 + y_n^2} = \frac{1}{2} \sqrt{x_n^2 + 2x_n + 1 + y_n^2} = \frac{1}{2} \sqrt{2 + 2x_n},$$

since $x_n^2 + y_n^2 = 1$. Since $x_1 = 0$ and $x_{n+1} = \frac{1}{2} \sqrt{2 + 2x_n}$, the first few terms in the sequence $\{x_n\}_{n \geq 1}$ are

$$0, \quad \frac{1}{2} \sqrt{2}, \quad \frac{1}{2} \sqrt{2 + \sqrt{2}}, \quad \frac{1}{2} \sqrt{2 + \sqrt{2 + \sqrt{2}}}.$$

Since $l_n = \sqrt{2 - 2x_n}$, the first few terms in the sequence $\{l_n\}_{n \geq 1}$ are

$$\sqrt{2}, \quad \sqrt{2 - \sqrt{2}}, \quad \sqrt{2 - \sqrt{2 + \sqrt{2}}}, \quad \sqrt{2 - \sqrt{2 + \sqrt{2 + \sqrt{2}}}}.$$

The sequence $\{2^n l_n\}_{n \geq 1}$ is increasing and tends towards π . The first few terms are

$$2\sqrt{2}, \quad 4\sqrt{2 - \sqrt{2}}, \quad 8\sqrt{2 - \sqrt{2 + \sqrt{2}}}, \quad 16\sqrt{2 - \sqrt{2 + \sqrt{2 + \sqrt{2}}}}.$$

Areas of Planar Regions

8. **Definition:** The area of a rectangle of base b and height h is equal to $A = bh$.

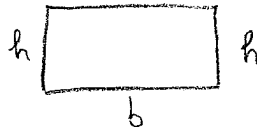

9. **Theorem:** The area of a triangle of base b and height h (measured in the direction perpendicular to the base) is equal to $A = \frac{1}{2}bh$.

Proof: A rectangle of base b and height h can be cut into two right-angled triangles of base b and height h , so the area of such a right-angled triangle is equal to $A = \frac{1}{2}bh$.

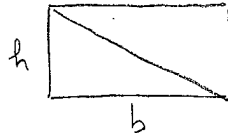

Now consider a triangle of base b and height h which is not right-angled. If the altitude lies inside the triangle then the triangle is cut by the altitude into two right-angled triangles both of height h . Let x be the base of one of the two triangles. Then the base of the other is $b - x$. The area of the original triangle is the sum of the areas of the two right-angled triangles: $A = \frac{1}{2}xh + \frac{1}{2}(b - x)h = \frac{1}{2}bh$. On the other hand, if the altitude lies outside the triangle then its area is the difference of the areas of two right-angled triangles of height h . Let x be the base of the smaller one. Then the larger has base $b + x$, and the area of the original triangle is $A = \frac{1}{2}(b + x)h - \frac{1}{2}xh = \frac{1}{2}bh$.

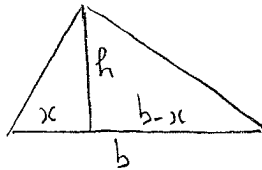

Alternatively, we can see that any triangle of base b and height h has the same area as a right-angled triangle of base b and height h as follows. The given triangle can be covered by thin horizontal rectangles. Without changing the total area, these rectangles can be slid horizontally until they cover a right-angled triangle with the same base and height as the given triangle.

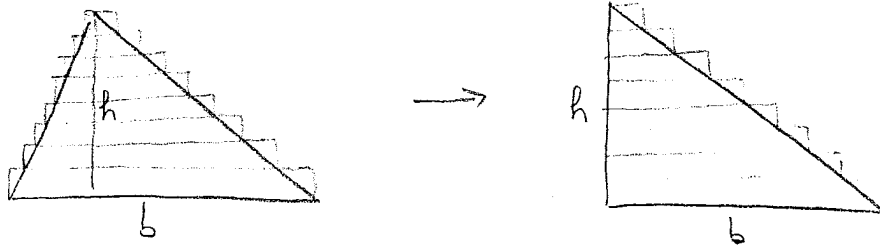

10. **Note:** Since we can find the area of a triangle, we can find the area of any polygonal region in the plane by cutting the polygonal region into triangles.

11. Note: Given any (reasonably well-behaved) region in the plane, we can approximate its area by covering it by small rectangles (and/or small triangles) and adding the areas of these rectangles (and/or triangles). We can find the exact area by taking a limit of these approximate areas as the size of the rectangles (and/or triangles) tends to zero.

12. Example: Find the exact area of the region given by $0 \leq x \leq 1$, $0 \leq y \leq x^2$ (the region which lies above the x -axis and below the parabola $y = x^2$ with $0 \leq x \leq 1$).

Solution: Choose $n + 1$ points $(x_k, y_k) = \left(\frac{k}{n}, \frac{k^2}{n^2}\right)$ for $k = 0, 1, 2, \dots, n$. Cover the given region by the n rectangles, where the k^{th} rectangle has vertices at $(x_{k-1}, 0)$, $(x_k, 0)$, (x_k, y_k) and (x_{k-1}, y_k) . The base of the k^{th} rectangle is $b_k = x_k - x_{k-1} = \frac{k}{n} - \frac{k-1}{n} = \frac{1}{n}$ and the height of the k^{th} rectangle is $h_k = y_k = \frac{k^2}{n^2}$, so the area of the k^{th} rectangle is

$$A_k = b_k h_k = \frac{1}{n} \cdot \frac{k^2}{n^2} = \frac{k^2}{n^3}.$$

The total area of the given region is

$$\begin{aligned} A &\cong A_1 + A_2 + A_3 + \dots + A_n \\ &= \frac{1}{n^3}(1^2 + 2^2 + 3^2 + \dots + n^2). \end{aligned}$$

We use the formula $1^2 + 2^2 + 3^2 + \dots + n^2 = \frac{n(n+1)(2n+1)}{6} = \frac{2n^3+3n^2+n}{6}$ (if you do not know this formula, you can try to prove it using induction) to get

$$A \cong \frac{2n^3 + 3n^2 + n}{6n^3} = \frac{1}{3} + \frac{1}{2n} + \frac{1}{6n^3}.$$

As n increases, our approximation becomes more and more accurate. The exact area is

$$A = \lim_{n \rightarrow \infty} \left(\frac{1}{3} + \frac{1}{2n} + \frac{1}{6n^3}\right) = \frac{1}{3}.$$

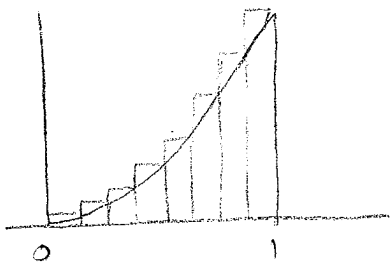

13. Theorem: The area of a circle of radius r is equal to $A = \pi r^2$. More generally, the area of a wedge in a circle of radius r making an angle θ at the center has area $A = \frac{1}{2}r^2\theta$.

Proof: A wedge in a circle of radius r , which subtends the angle θ at the center, can be cut into thin wedges which can be reassembled to form (or at least almost form) a rectangle of base $b = \frac{1}{2}r\theta$ and height $h = r$, so the area is $A = bh = \frac{1}{2}r\theta \cdot r = \frac{1}{2}r^2\theta$.

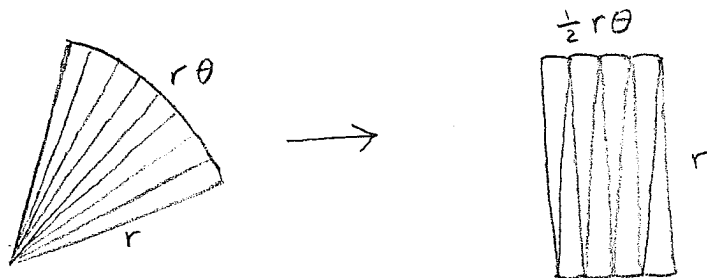

14. Theorem: The area of an ellipse with semi-major axis a and semi-minor axis b is equal to $A = \pi ab$.

Proof: Cover a unit circle by thin horizontal rectangles with total area π (or arbitrarily close to π). Scale horizontally by a factor of a to obtain rectangles, with a total area of πa , which cover an ellipse with semi-major axis a and semi-minor axis 1. Then scale vertically by a factor b to obtain rectangles, with total area πab which cover an ellipse with semi-major axis a and semi-minor axis b .

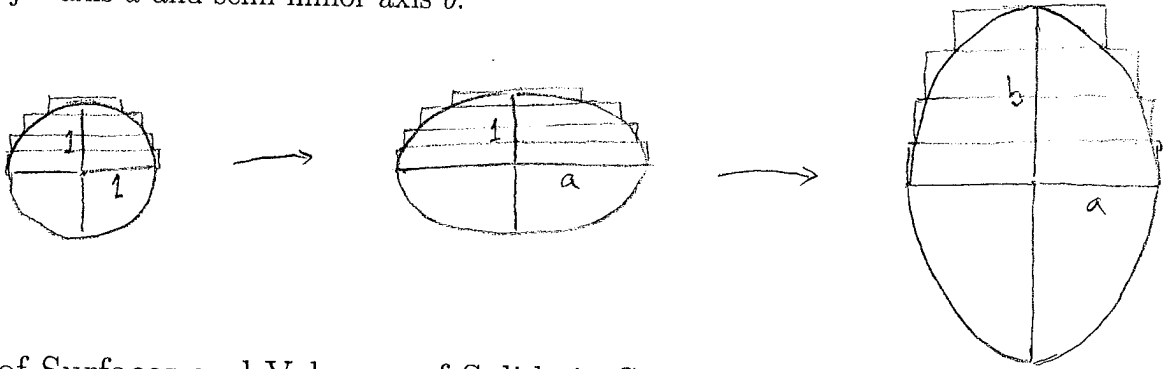

Areas of Surfaces and Volumes of Solids in Space

15. Definition: The **volume** of a rectangular box of length l , width w and height h is equal to $V = lwh$.

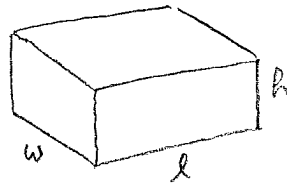

16. Note: Given any (reasonably well-behaved) solid in space, we can approximate its volume by covering it with small rectangular boxes and adding their volumes. We can find the exact volume by taking a limit of the approximate volumes as the size of the boxes tends to zero.

17. Theorem: The area of the lateral surface of a right cylinder of height h with a base (of any shape) of perimeter l is equal to $A = lh$.

Proof: The lateral surface of the cylinder can be cut along a vertical line then flattened out into a rectangle with base l and height h .

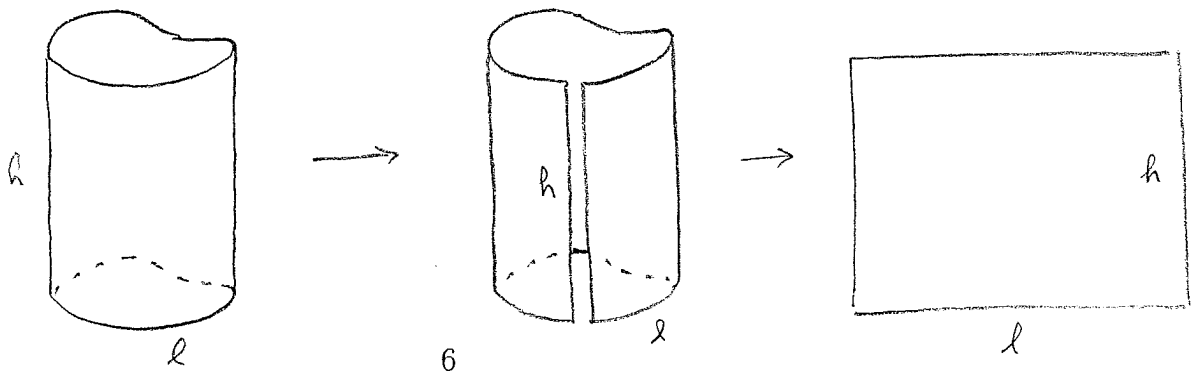

18. Theorem: *The volume of a cylinder (possibly leaning) with a base of area A and height h (measured in the direction perpendicular to the plane of the base) is equal to $V = Ah$.*

Proof: First consider the case of a right cylinder. The base of the cylinder can be covered by many small rectangles whose total area is equal to (or is arbitrarily close to) A . Say there are n rectangles and the area of the k^{th} rectangle is A_k so that $A_1 + A_2 + \dots + A_n = A$. Then the right cylinder is covered by n rectangular boxes, all of height h , and the volume of the k^{th} box is equal to $V_k = A_k h$. The total volume V of the cylinder is equal to (or at least almost equal to) the sum of the volumes of these boxes, so

$$V = V_1 + V_2 + \dots + V_n = (A_1 + A_2 + \dots + A_n) h = Ah.$$

Now consider an arbitrary (possibly leaning) cylinder with base area A and height h . Slice the cylinder into thin horizontal slices then (without changing the volume of any of the slices) slide them horizontally to form a right cylinder with the same base and height as the original (possibly leaning) cylinder.

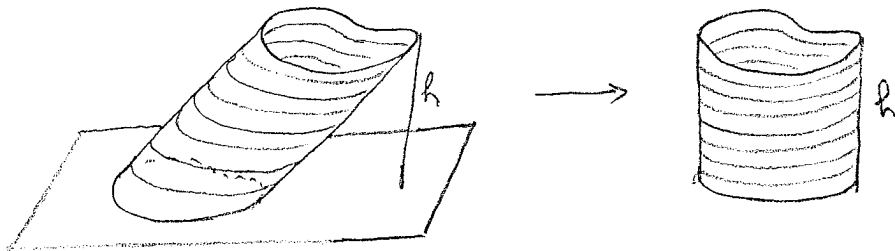

19. Theorem: *The area of the lateral surface a right-circular cone of base radius r and of slant-length s (from the vertex along the lateral side to the base) is equal to $A = \pi r s$. More generally, the area of a truncated right-circular cone of average radius r and slant-length s is equal to $A = 2\pi r s$.*

Proof: The lateral surface of right circular cone of base-radius r and slant-length s can be cut into thin triangles which can (almost) be reassembled to form a rectangle of base $b = \pi r$ and height $h = s$, so the area is $A = bh = \pi r s$. Similarly, a truncated right-circular cone of average radius r and slant-length s can be cut into thin trapezoids which can (almost) be reassembled to form a rectangle of base $2\pi r$ and height s .

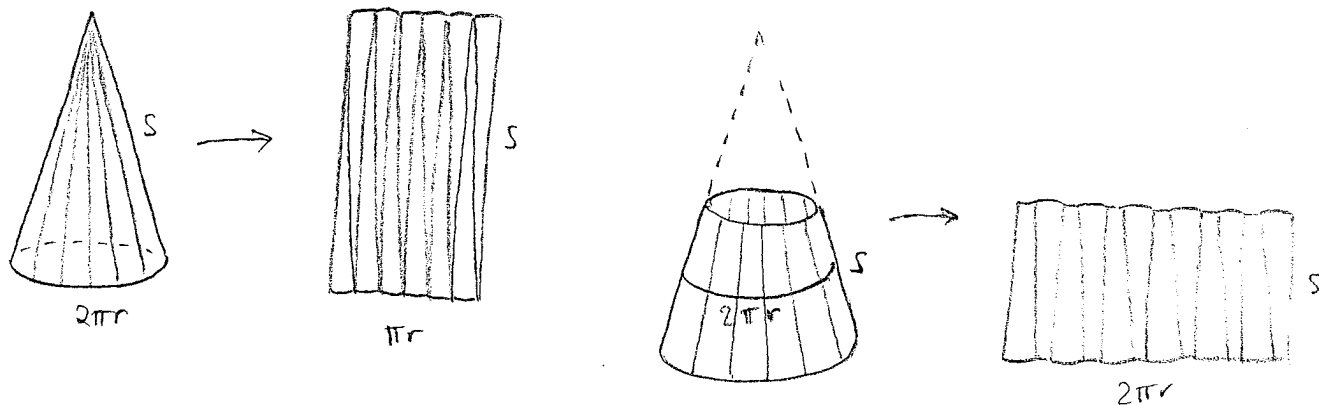

20. Theorem: The volume of a cone (possibly leaning) with a flat base of area A and height h (measured perpendicular to the plane of the base) is equal to $V = \frac{1}{3}Ah$.

Proof: A unit cube can be cut into 6 square-based pyramids, each with a unit square base, which all have their vertex at the center of the cube. Thus the volume of a square-based pyramid with a unit square base and height $\frac{1}{2}$ is equal to $V = \frac{1}{6}$. By scaling by a factor of a in the x -direction, a factor of b in the y -direction, and a factor of $2h$ in the vertical z -direction, we see that the volume of a right pyramid of height h , with a rectangular base of side lengths a and b , is equal to $V = \frac{1}{3}abh$.

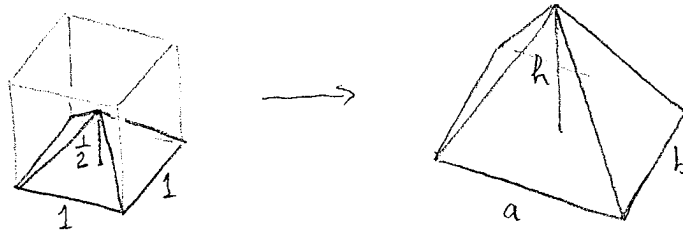

Given any pyramid (possibly leaning) of height h with a rectangular base of side lengths a and b , we can slice the given pyramid into thin horizontal slices, then without changing the total volume we can slide these slices horizontally to obtain a right rectangular-based pyramid with the same height and base. Thus the formula $V = \frac{1}{3}abh$ also holds for a leaning pyramid of height h with a rectangular base of side lengths a and b .

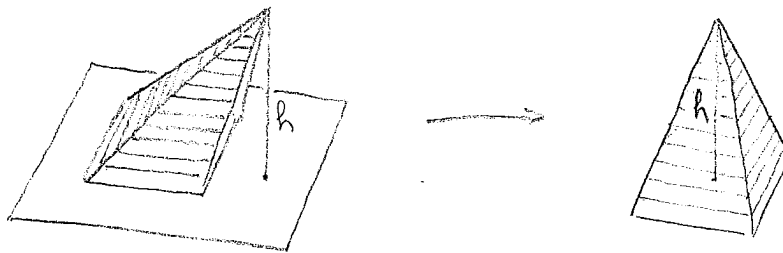

Finally, given a cone of height h with a base of any shape of area A , we can cover the base by thin rectangles of total area A , then we can use these rectangles as the bases of thin leaning rectangular-based pyramids which cover the given pyramid. If there are n thin rectangles and the k^{th} thin rectangle has area A_k so that $A_1 + A_2 + \dots + A_n = A$, then the k^{th} thin pyramid has volume $V_k = \frac{1}{3}A_k h$, and the total volume is

$$V = V_1 + V_2 + \dots + V_n = \frac{1}{3}(A_1 + A_2 + \dots + A_n)h = \frac{1}{3}Ah.$$

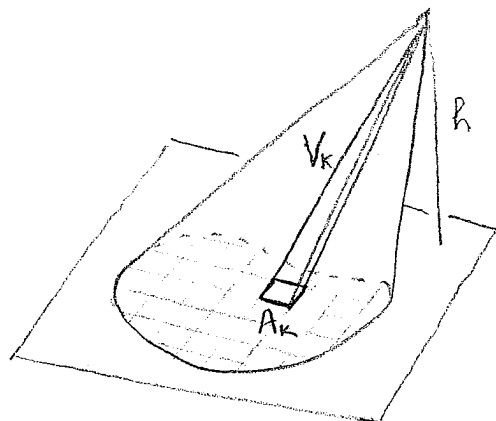

21. Definition: A **slice** of thickness h on the surface of a sphere is the portion of the surface of the sphere which lies between two parallel planes which are separated by a distance h units.

22. Theorem: The area of the entire surface of a sphere of radius r is equal to $A = 4\pi r^2$. More generally, the area of a slice of thickness h of the surface of a sphere of radius r is equal to $A = 2\pi r h$.

Proof: Given a slice of thickness h of the surface of a sphere of radius r , cut this slice into many thin slices. Each thin slice of the surface of the sphere may be approximated by a thin truncated right-circular cone. Consider one thin slice of thickness Δx with x , y , Δy and Δl as shown below.

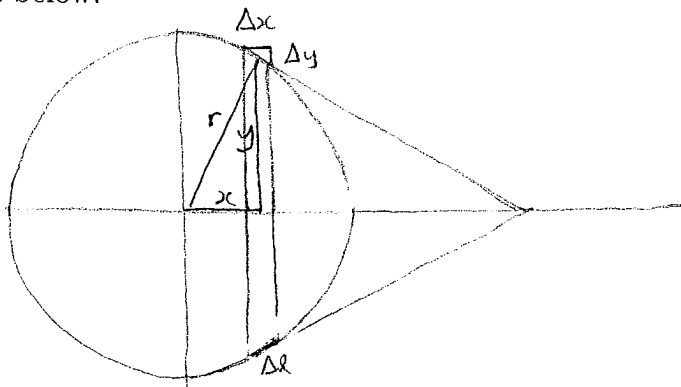

Note that the right-angled triangle with sides x , y and r is similar to the right-angled triangle with sides Δy , Δx and $\Delta l = \sqrt{\Delta x^2 + \Delta y^2}$, so we have $\frac{\Delta y}{\Delta x} = \frac{x}{y}$. The area of this thin slice is

$$\begin{aligned} \Delta A &= 2\pi y \Delta l = 2\pi y \sqrt{\Delta x^2 + \Delta y^2} = 2\pi y \sqrt{1 + \left(\frac{\Delta y}{\Delta x}\right)^2} \Delta x \\ &= 2\pi y \sqrt{1 + \left(\frac{x}{y}\right)^2} \Delta x = 2\pi y^2 + x^2 \Delta x = 2\pi r \Delta x. \end{aligned}$$

If the original slice of thickness h is cut into n thin slices, and the k^{th} thin slice has thickness h_k with $h_1 + h_2 + \dots + h_n = h$, then the area of the k^{th} thin slice is $A_k = 2\pi r h_k$, so the total area of the slice of thickness h is

$$A = A_1 + A_2 + \dots + A_n = 2\pi (h_1 + h_2 + \dots + h_n) = 2\pi r h.$$

We obtain the area of the entire surface of the sphere by taking $h = 2r$.

23. Definition: A **great circle** on a sphere is the intersection of the sphere with a plane through the origin. The edges of a **spherical triangle** are arcs of great circles. The **spherical distance** between two points on a sphere is measured along an arc of a great circle. If p is a point on a sphere of radius r , then the **spherical circle** of radius s centered at p is the set of points on the sphere whose spherical distance from p is equal to s . The region on the surface of a sphere which lies inside a spherical circle is called a **spherical disc** or a **spherical cap**.

24. Theorem: Let C be a spherical circle of radius s on a sphere of radius r . Then the circumference of C is equal to $l = 2\pi r \sin \frac{s}{r}$ and the area of the spherical cap inside C is equal to $A = 2\pi r^2 (1 - \cos \frac{s}{r})$.

Proof: From the picture below, we see that the spherical circle C of radius s is equal to a flat circle in \mathbf{R}^3 of radius $r \sin \theta$ where $s = r\theta$ so that $\theta = \frac{s}{r}$, and so the circumference of the spherical circle is

$$l = 2\pi r \sin \theta = 2\pi r \sin \frac{s}{r}.$$

From the same picture, we see that the spherical cap inside C is equal to a slice of thickness $h = r - r \cos \theta$ on the sphere of radius r , so its area is

$$A = 2\pi r(r - r \cos \theta) = 2\pi r^2 (1 - \cos \frac{s}{r}).$$

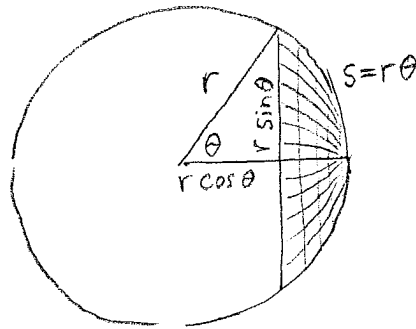

25. Theorem: The area of a spherical triangle on a sphere of radius r , whose interior angles are α , β and γ , is equal to $A = r^2(\alpha + \beta + \gamma - \pi)$.

Proof: Consider a wedge of angle α on the sphere, as shown below. This wedge covers a proportion of $\frac{\alpha}{\pi}$ of the total surface area of the sphere, so its area is

$$A_\alpha = \frac{\alpha}{\pi} \cdot 4\pi r^2 = 4r^2 \alpha.$$

Consider three such wedges, of angles α , β and γ , as shown. These wedges cover the entire surface of the sphere once, and they cover the given spherical triangle an additional two times, and they cover another congruent spherical triangle (on the opposite hemisphere) an additional two times, so writing A for the area of the spherical triangle, we have

$$\begin{aligned} 4\pi r^2 + 4A &= A_\alpha + A_\beta + A_\gamma = 4r^2(\alpha + \beta + \gamma) \\ 4A &= 4r^2(\alpha + \beta + \gamma) - 4\pi r^2 \\ A &= r^2(\alpha + \beta + \gamma - \pi). \end{aligned}$$

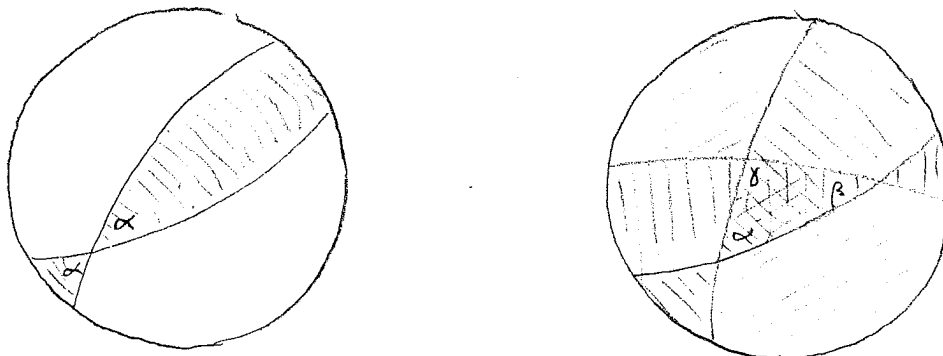

26. Theorem: The volume of a sphere of radius r is equal to $V = \frac{4}{3}\pi r^3$. More generally, the volume of a spherical cone whose base is a region of area A on the surface of the sphere and whose vertex is at the center of the sphere, is equal to $V = \frac{1}{3}Ar$.

Proof: Given a spherical cone whose base is a region of area A on the surface of a sphere of radius r and whose vertex is at the center, we can cover the spherical region by many small flat (or at least almost flat) polygons, and use these flat polygons as the bases of many thin flat-based cones, all of height r , which cover the spherical cone. If there are n polygons, and the k^{th} polygon has area A_k so that $A_1 + A_2 + \cdots + A_n = A$, then the k^{th} thin cone has volume $V_k = \frac{1}{3}A_k r$ so the total volume is

$$V = V_1 + V_2 + \cdots + V_k = \frac{1}{3}(A_1 + A_2 + \cdots + A_n)r = \frac{1}{3}Ar.$$

To obtain the volume of the entire sphere, note that the sphere is equal to the spherical cone whose base is the entire surface of the sphere, so we take $A = 4\pi r^2$ and we obtain $V = \frac{1}{3}Ar = \frac{4}{3}\pi r^3$.

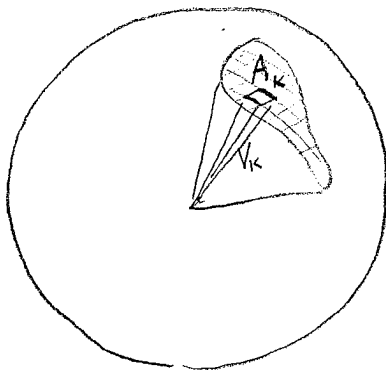

27. Theorem: The volume of an ellipsoid with semi-axes of lengths a , b and c is equal to $V = \frac{4}{3}\pi abc$.

Proof: This formula is obtained by scaling the unit sphere, which has volume $\frac{4}{3}\pi$, by a factor of a in the x -direction, b in the y -direction, and c in the z -direction.

