

Grade 7/8 Math Circles

Winter 2013

Fibonacci Series

Fibonacci Numbers

In the early 1200's an Italian mathematician called Fibonacci discovered a very interesting, and now famous, number pattern.

Fibonacci Rabbits

Fibonacci wants to save some money to buy a boat. So he decided he will sell rabbit's fur for money. He buys a pair of rabbits and every month they give birth to a new pair of rabbits. Assuming a rabbit must be two months before she can give birth, how many pairs of rabbits will he have to sell after a year?

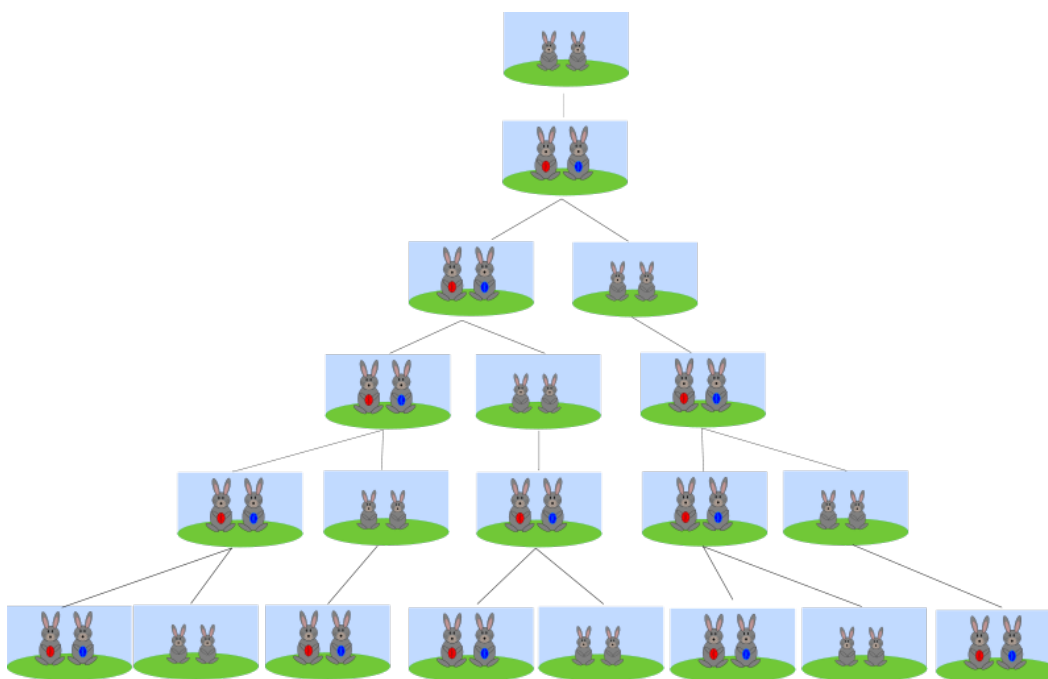

(Every row represents one month)

The pattern starts with the numbers 1, 1, 2, 3, 5, 8, How many rabbits would there be after 7 months?

1, 1, 2, 3, 5, 8,

What's the pattern?

The pattern is:

Let F_1 be the first Fibonacci number: 1

Let F_2 be the second Fibonacci number: 1

Let F_3 be the third Fibonacci number: 2, and so on

The formula to find the nth Fibonacci number is:

$$F_n = F_{n-2} + F_{n-1}$$

Exercise

Find the number of rabbits after:

a) 10 months? _____

b) a year? _____

c) 15 months? _____

Fibonacci Spiral

Let's draw two squares of area 1^2 , and place one on top of the other.



Now let's draw one square of area 2^2 . And position it so it fits against the two squares of area 1.

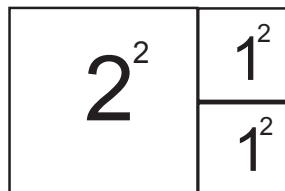

Next, a square of area 3^2 , and position it so it fits against the other squares.

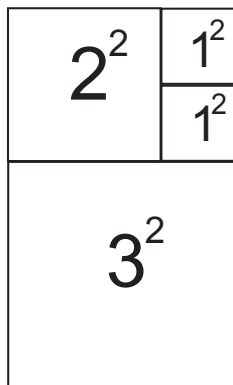

We choose the areas to be the squares of the Fibonacci numbers. If we continue to draw these squares, and then draw a curve across the diagonal of each square, we will end up with something that looks like this:

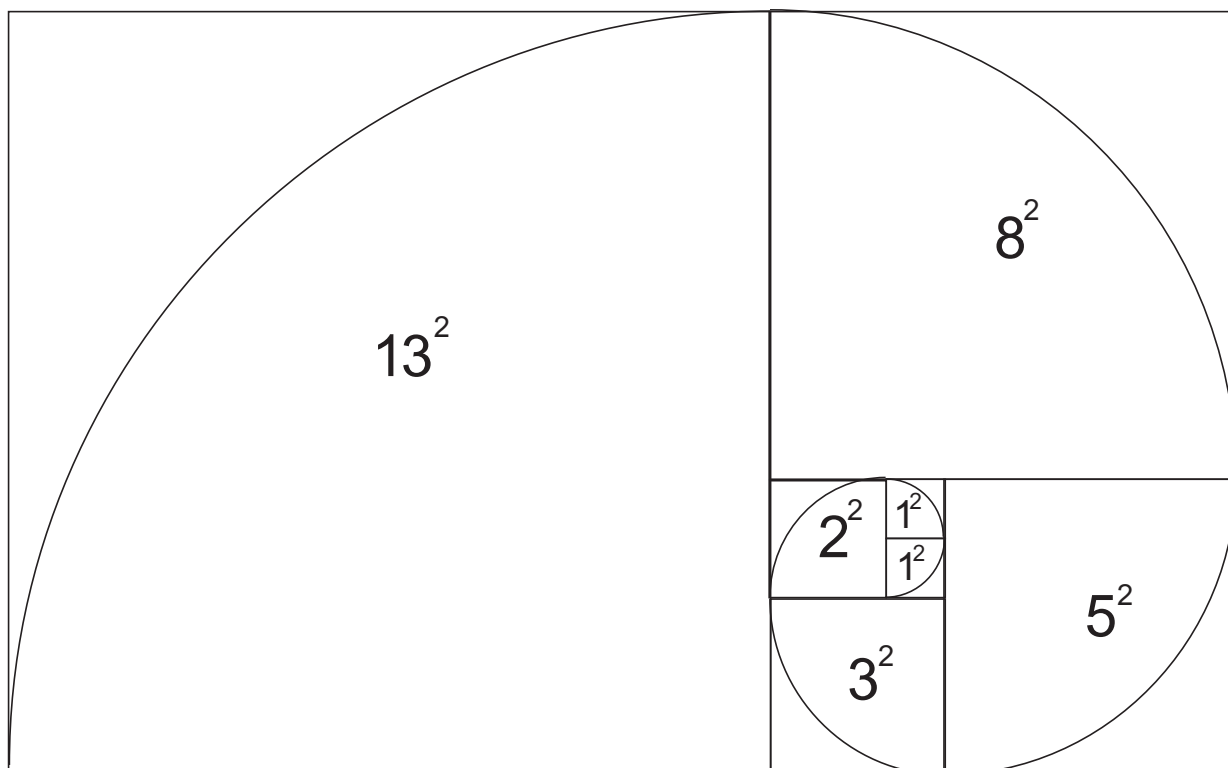

The Fibonacci Spiral shows up continuously in nature because plants naturally grow new cells in spirals. Can you identify the Fibonacci Spirals in the following plants?

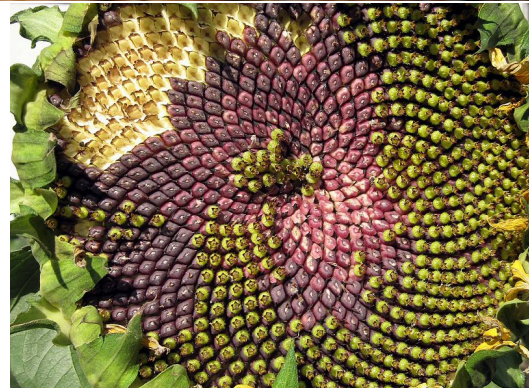

The Golden Ratio

Why do plants grow in spirals? Because it is the most efficient use of space. A spiral will use up less space than a line for example. But even though they will use up less space than a line, some spirals can still waste space.

Consider the seeds of a sunflower. How many turns should each new seed be placed so that the seeds can be the most compact, i.e., waste the least amount of space?

This is the same as saying 1.618... because the 1 is one full turn that will bring you back to the same spot you started from.

If we consider these turns in terms of angles, $0.618... = 222.5^\circ$ going counter-clockwise. Going clockwise, this angle is 137.5° .

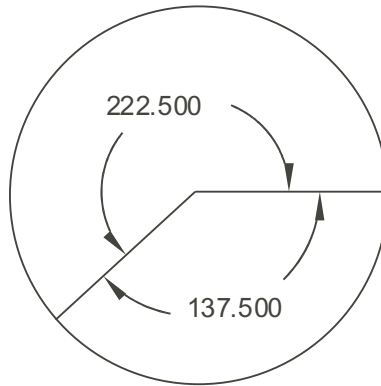

Now let's take the ratio of the Fibonacci numbers.

$$\frac{1}{1} = 1, \frac{2}{1} = 2, \frac{3}{2} = 1.5, \frac{5}{3} = 1.67, \frac{8}{5} = 1.6, \frac{13}{8} = 1.625, \frac{21}{13} = 1.615, \dots, \frac{233}{144} = 1.61805, \dots$$

Slowly, the ratios are decreasing but are seeming to stay around the value of 1.61 - 1.62. Take the next 3 ratios and see what you get. A *ratio* is just taking a fraction of two numbers.

You can continue to do this and the numbers will continue to approach 1.618..., the value plants use to decide how much to turn by to be the most compact. This is why plants grow in the Fibonacci Spiral!

This value is called the **Golden Ratio**. It is represented by the greek letter φ (pronounced phi), and is an irrational number.

Irrational Numbers

An *irrational* number, is a number that **cannot** be written as a ratio, meaning you can not write it as a simple fraction.

You can also say an irrational number is _____

For example,

$$1.5 = \frac{3}{2}, 0.75 = \frac{3}{4}, 0.25 = \frac{1}{4}$$

are all simple fractions. You can take the decimal and change it to a fraction. So they are called *rational* numbers.

But, you can not do this with irrational numbers. For example, π is an irrational number. You can not write π as a rational number because the number never ends. However, there is a popular estimate for π which is:

$$\frac{22}{7} = 3.142857\dots$$

And so, there is also an formula which gives a good estimate for the Golden Ratio.

$$\varphi = \frac{1 + \sqrt{5}}{2} = 1.618034$$

Golden Rectangle

If we try to make a rectangle with dimensions which have a ratio of 1.618034 (The Golden Ratio), you get what is called the **Golden Rectangle**.

To draw this start with a 1 by 1 square. Then draw a line from the midpoint of one line to the opposite corner, and extend one side of the square by the length of this line to look like so:

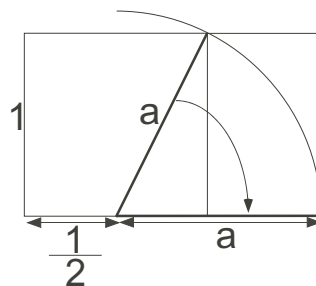

Exercise

What is the length of a?

Exercise

A rectangle has dimensions 0.8 x 1.2944272. Is this rectangle a Golden Rectangle?

The Golden Rectangle is the most esthetically pleasing rectangle in the world (or so most architects believe). Many features on animals, as well as some famous beautiful paintings and structures seem to have the Golden Rectangle within their design.

Wait!

What if I want to find the 100th term of the Fibonacci numbers! Do I have to add all the numbers until I reach the 100th?!

Happily no! Another thing that is quite special about the Golden Ratio, is we can use the formula for its approximation to give us any of the Fibonacci Numbers!

$$F_n = \frac{\varphi^n - (1 - \varphi)^n}{\sqrt{5}}$$

Problem Set

1. What is the 18th Fibonacci number?
2. Take a look at the following number pattern:

1, 3, 4, 7, 11, ...

What would the next 3 values be?

3. Circle all of the irrational numbers.

- | | |
|--------------------|---------------------|
| a) 0.25 | f) $\sqrt{3}$ |
| b) 1.75 | g) 2.71828182845... |
| c) 1.2569874321856 | h) $1.\bar{3}$ |
| d) $\sqrt{2}$ | i) $\sqrt{5}$ |
| e) $\frac{8}{5}$ | j) $\sqrt{25}$ |

4. Janet wants to become a famous scenery painter, but in order to do so her paintings have to be liked. She paints segments of her scenery in 5 cm by 8.09017 cm grids. Will her painting be esthetically appealing so that people will like her work?
5. Draw the next two figures that would follow the pattern. No two squares of the same colour should be touching. There are multiple answers.

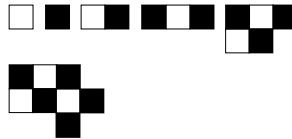

6. Carl is hired to build a brick wall. His conditions are:
 - every brick must have a length double the size of its width (i.e. every brick is the same size)
 - the wall has to be 2 units tall

If he uses one brick, he can only build the wall in one way. If he uses two bricks he can build the wall in 2 ways. If he uses three bricks he can build the wall in 3 ways.

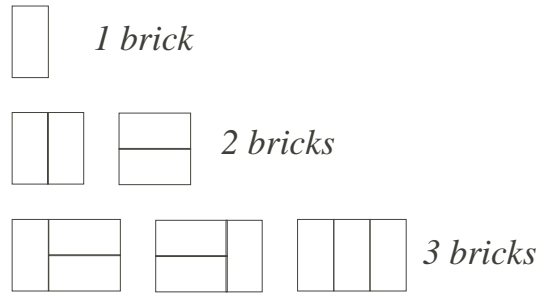

How many ways can he build the wall if he uses:

- a) 4 bricks?
 - b) 5 bricks?
 - c) 10 bricks?
7. Joseph owns a boat building company where he builds canoes and sailboats. Canoes take 1 month to build, and sailboats take 2. His workspace only has room to build one boat at a time but he has lots of customers ordering boats! He decides he will close down his workspace soon to upgrade it for more room, but until then he wants to get as many orders done as he can, if order matters.
- a) If he waits 1 month to upgrade his workspace, in how many ways can he build how many boats?
 - b) What if he waits 2 months?
 - c) 3 months?
 - d) 4 months?
 - e) If he wants to have 144 combinations in which he can build his boats, how many months should he wait?
8. Ted is an architect and he is told to build either single houses, or semi-detached houses on a street. Streets have a certain amount of lots that houses can be built on. Single houses take up one lot, and semi-detached houses take up two. How many different ways can he plan to build the houses on a street if order matters and the street has:
- a) 1 lot free?
 - b) 2 lots free?
 - c) 3 lots free?
 - d) 5 lots free?
 - e) If he wants to 21 plans for houses on Water Street, how many free lots does he need?
9. Did you notice questions 7, 8, 9 were similar? Why? What is needed in order to come up with a Fibonacci problem?

10. Consider Fibonacci's Rabbits. How many grown-up female rabbits would there be after 10 months? Male? What do you notice?

11. Would you believe that not all honeybees have two parents? Well its true! Male bees only have a mom, but female bees have both a mom and a dad. Looking at the family tree of a male honeybee, can you figure out how many great-great-great-great-grand parents the boy bee at the bottom had?

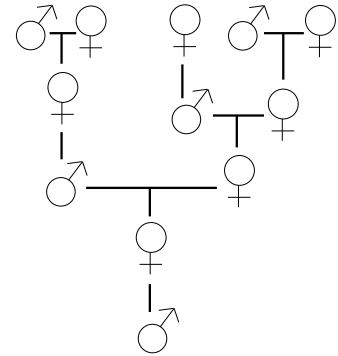

12. What is the pattern between these numbers?

4181, 6765, 10946, 17711 ...

13. What is the 20th number in the Fibonacci Series?

14. Given that the 8th number in a Fibonnaci-like number pattern is 42, and the 5th number is 10, what is the first number in the pattern?