



Grade 7/8 Math Circles

Fall 2014 - Nov.4/5

The Pythagorean Theorem

Introduction

A right triangle is any triangle with a 90° angle. Let's take a look at one!

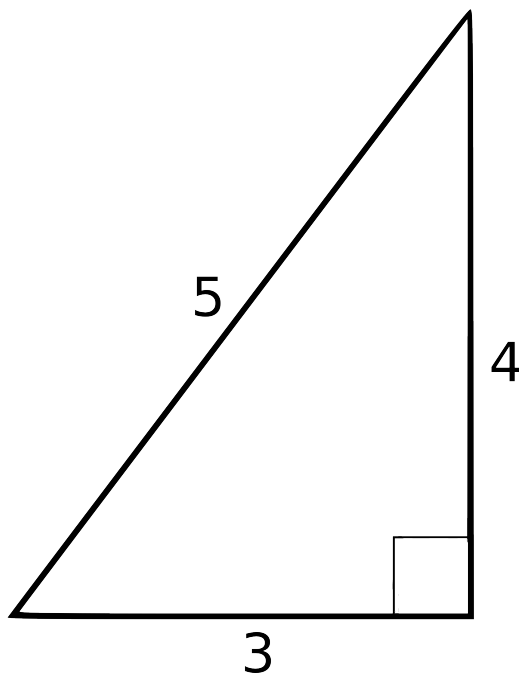

At first glance, there doesn't seem to be anything special about this triangle; but there **IS** something special about the lengths of its 3 sides. To illustrate, let's take the square of each side, from the triangle above, and draw some pictures!

These are the squares of each respective side of the right triangle from the page before:

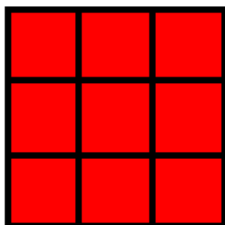

$$3^2$$

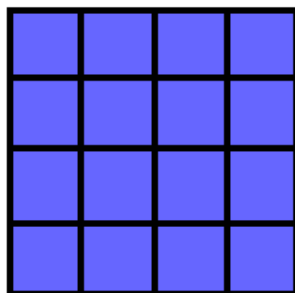

$$4^2$$

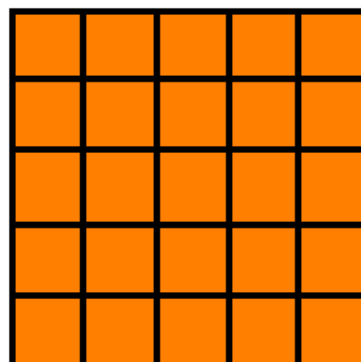

$$5^2$$

Just because we can, let's see if our two smaller squares fit into the bigger one:

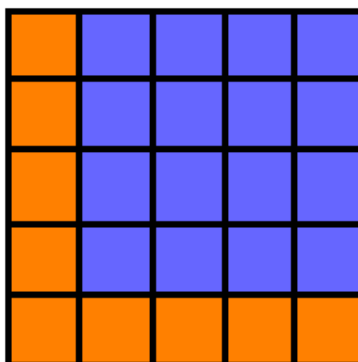

Now, it doesn't look like we could fit our 3 by 3 square in there; but notice that there are 9 orange, 1 by 1 squares left, which is the same amount of red, 1 by 1 squares that make up our 3 by 3 square! Let's break apart our red, 3 by 3 square and fit it into the rest of our 5 by 5 square above.

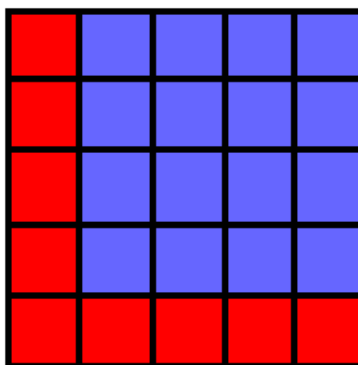

Well, it seems like the squares of the two smaller sides of the right triangle can be used to make up the square of the biggest side. In particular, $3^2 + 4^2 = 5^2$.

The Pythagorean Theorem

What we discovered in the example above is in fact true for any right triangle.

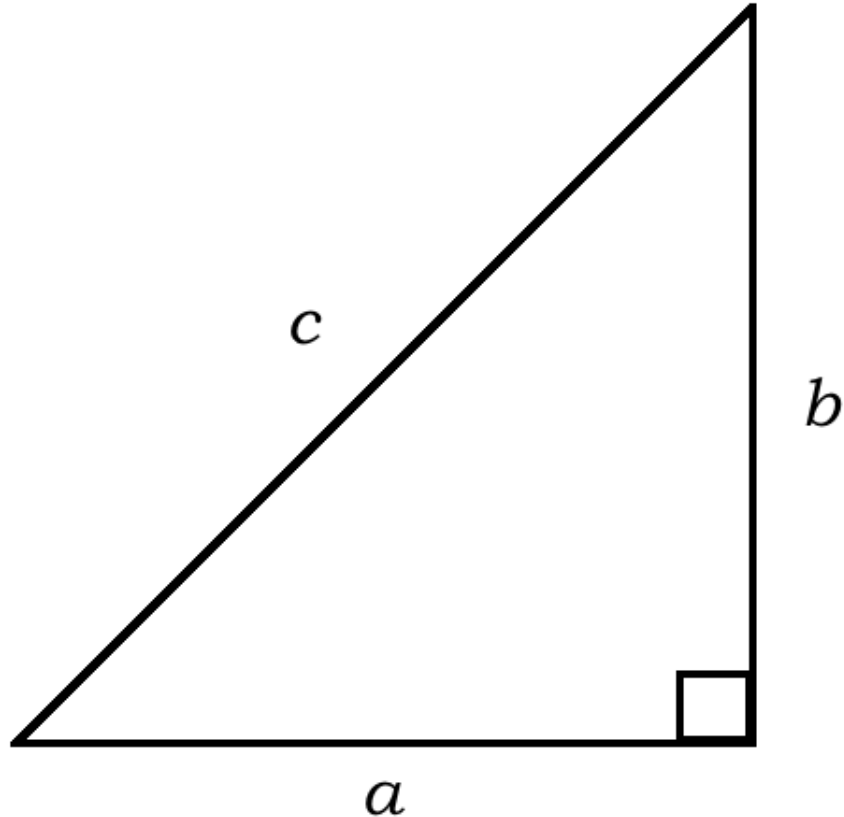

In particular, for any right triangle, if a and b are the lengths of the two sides that meet at the right angle (90°), and c is the length of the longest side, opposite of the right angle, then $a^2 + b^2 = c^2$.

Let's introduce some triangle terminology so we can make this theorem look nicer.

Triangle Terminology:

vertex - any corner of the triangle.

adjacent sides - two sides are said to be adjacent if they meet at a common vertex.

legs - the two adjacent sides of a right triangle that meet at the right (90°) angle.

hypotenuse - the longest side of a right triangle, opposite of the right angle.

The Proof

Prove the following:

For any right triangle, if a and b are the lengths of the legs, and c is the length of the hypotenuse, then $a^2 + b^2 = c^2$.

We will prove this theorem by using pictures. Let's arrange 4 of the same right triangles to get the figure below:

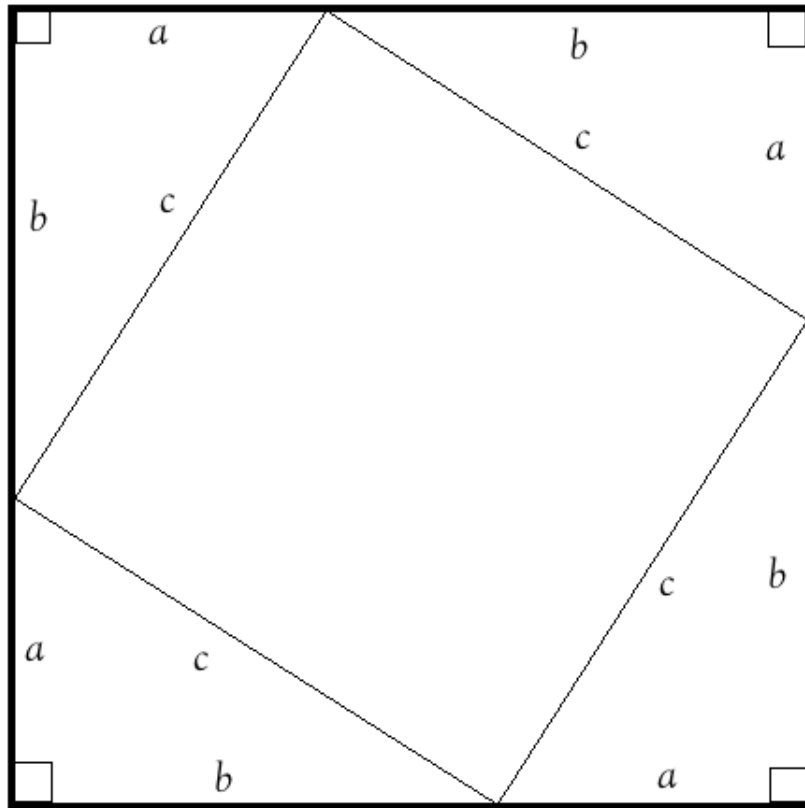

Notice that the 4 right triangles have the same adjacent sides a and b that meet at a 90° angle. So, because the corresponding sides of each triangle have equal length and meet at the same angle, they are all the same triangle (This follows from the axiom in math called “side, angle, side” or **SAS**). More importantly, this tells us that these 4 triangles have the same hypotenuse. We'll call the length of this hypotenuse c .

Well, if the 4 side lengths of the figure in the middle are all c , this tells we have a square. The shaded region represents the area of the square in the middle of our figure. This area is equal to $c * c$ or c^2 .

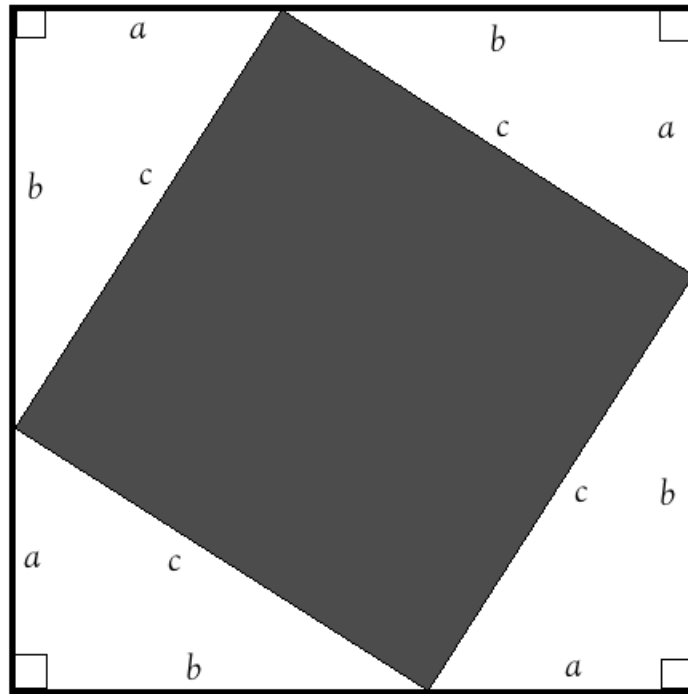

Now, remember that we need to show that $a^2 + b^2 = c^2$. So, because we can, let's play around with the arrangement of the 4 right triangles in the figure above:

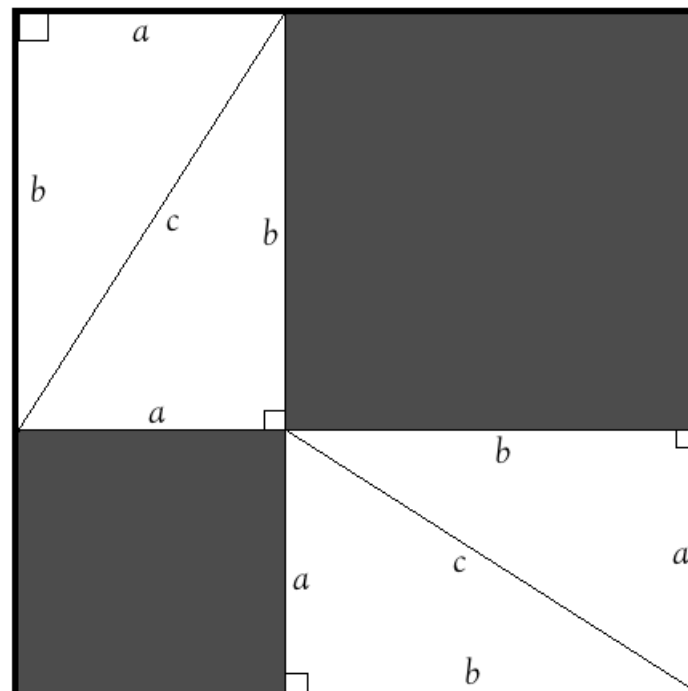

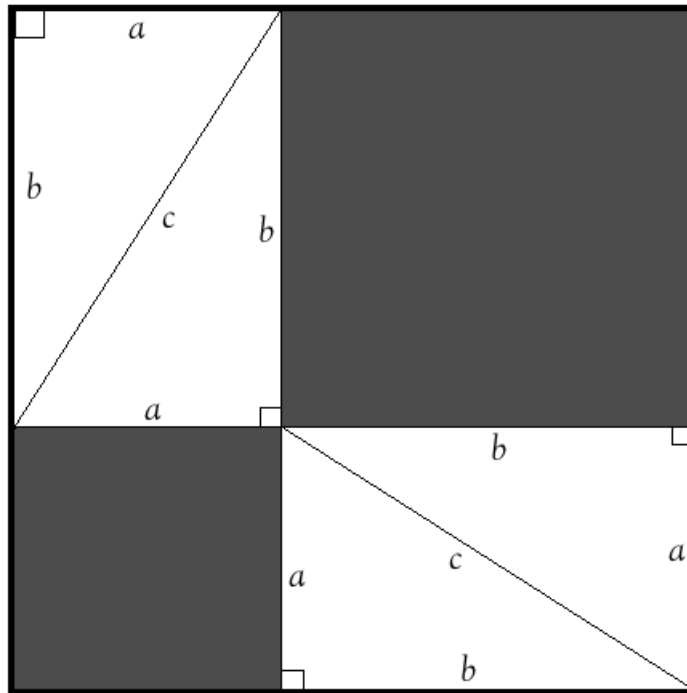

Notice that the total area of our figure did not change, because all we did was move the right triangles around. Then, since the area of the 4 right triangles has also not changed, this tells us that the area of our two shaded regions must equal the area of our original shaded region, c^2 . But, the area of the smaller shaded region is just $a*a$, or a^2 , and the area of the larger shaded region is just $b*b$, or b^2 .

Therefore, we conclude that $a^2 + b^2 = c^2$.

□

Test the Pythagorean Theorem on the triangles below:

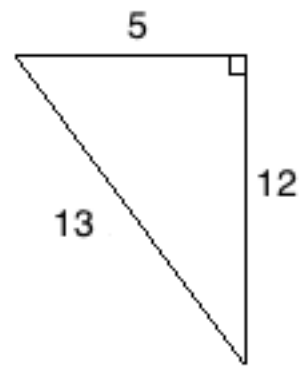
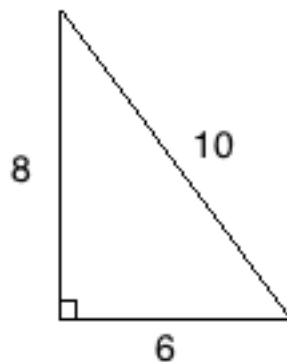

Applying the Pythagorean Theorem

Now that we understand the relationship between the lengths of the sides for right triangles, we can solve for the length of any side if we are given the length of the two other sides:

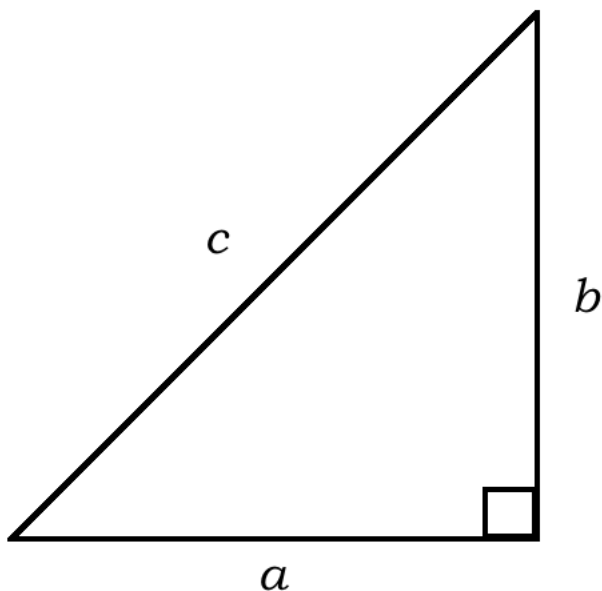

If $a^2 + b^2 = c^2$, then:

1. $c = \sqrt{a^2 + b^2}$

2. $a = \sqrt{c^2 - b^2}$

3. $b = \sqrt{c^2 - a^2}$

Exercise: Prove that the above equations are true, given that $a^2 + b^2 = c^2$.

1. $c^2 = a^2 + b^2 \rightarrow \sqrt{c^2} = \sqrt{a^2 + b^2} \rightarrow c = \sqrt{a^2 + b^2}$

2. $a^2 + b^2 = c^2 \rightarrow a^2 = c^2 - b^2 \rightarrow \sqrt{a^2} = \sqrt{c^2 - b^2} \rightarrow a = \sqrt{c^2 - b^2}$

3. $a^2 + b^2 = c^2 \rightarrow b^2 = c^2 - a^2 \rightarrow \sqrt{b^2} = \sqrt{c^2 - a^2} \rightarrow b = \sqrt{c^2 - a^2}$

Exercise

Solve for the length of the missing side. Assume the unit of measure in centimetres.

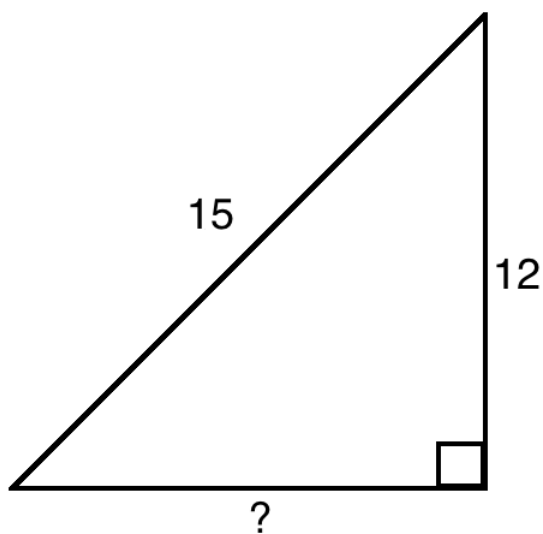

Let a be the length of the missing side. then,

$$\begin{aligned} a &= \sqrt{15^2 - 12^2} \\ &= \sqrt{225 - 144} \\ &= \sqrt{81} \\ &= 9 \end{aligned}$$

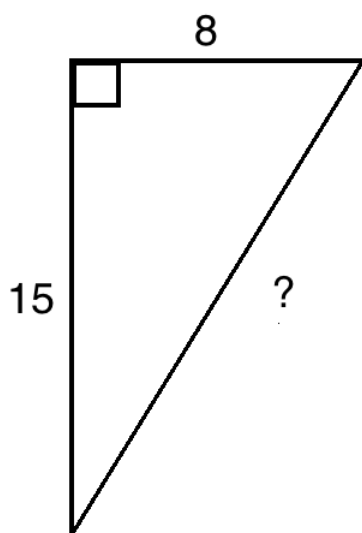

Let c be the length of the missing side. then,

$$\begin{aligned} c &= \sqrt{8^2 + 15^2} \\ &= \sqrt{64 + 225} \\ &= \sqrt{289} \\ &= 17 \end{aligned}$$

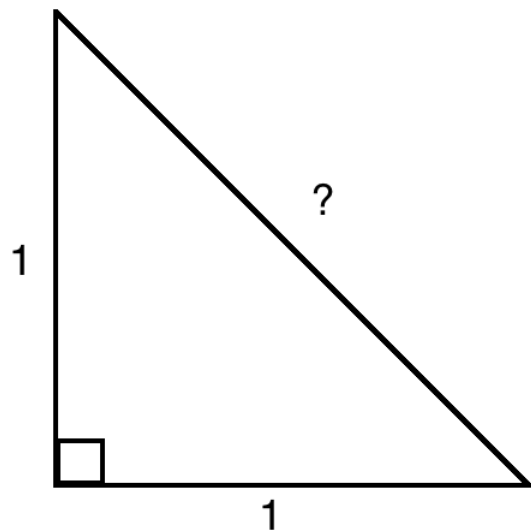

Let c be the length of the missing side. then,

$$\begin{aligned} c &= \sqrt{1^2 + 1^2} \\ &= \sqrt{1 + 1} \\ &= \sqrt{2} \\ &= 1.4142135... \end{aligned}$$

Something interesting about $\sqrt{2}$

The last length we solved for in the exercise above was $\sqrt{2} = 1.4142135\dots$, which is an **irrational number**- an irrational number is just a number that we cannot express as a simple fraction, the same way we can express 0.5 as $\frac{1}{2}$. But, with the Pythagorean Theorem we can visually see the exact **distance** of $\sqrt{2}$.

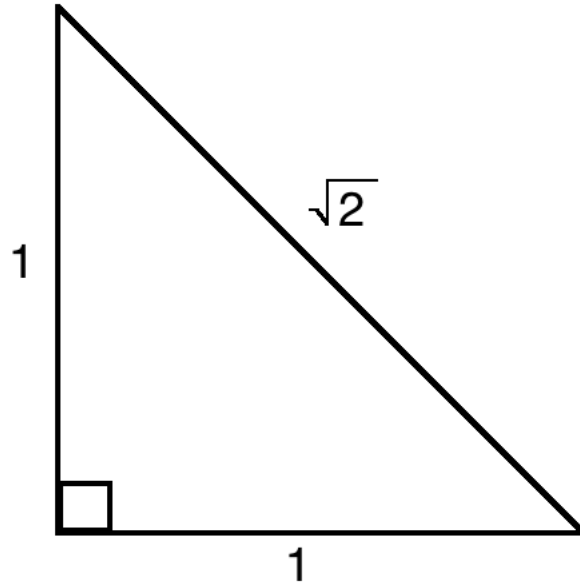

In fact, there are many irrational numbers we can express as exact distances. **The Spiral of Theodorus** shows that we can visualize the exact distance of irrational numbers. The hypotenuse of each triangle becomes the leg of the next triangle in the spiral, with the shorter leg always having a distance of 1:

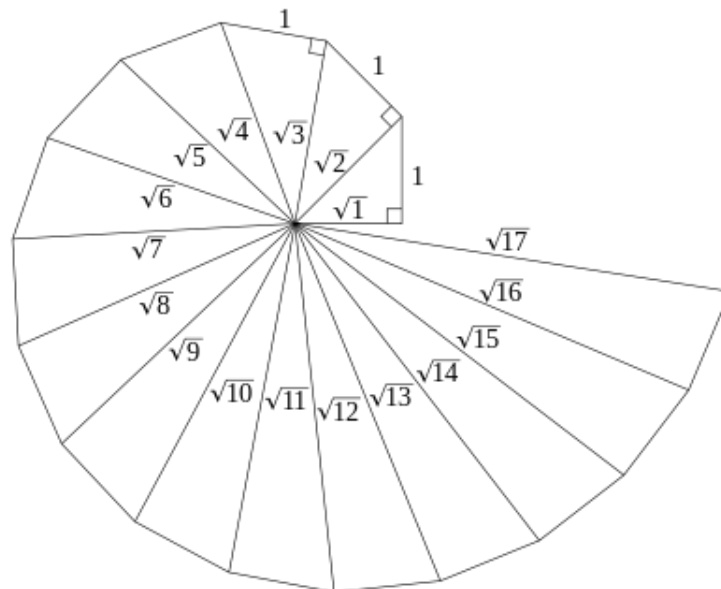

Pythagorean Triple

A Pythagorean Triple is a set of 3 numbers that form a perfect solution to the Pythagorean Theorem.

The easiest triple to think of is

$$3 \ 4 \ 5$$

We can take any **multiple** of this triple (multiply all 3 numbers by the same number) and still have the Pythagorean Theorem work properly. Multiples of this triple are

$$6 \ 8 \ 10$$

$$9 \ 12 \ 15$$

$$12 \ 16 \ 20$$

There are also other Pythagorean Triples that **are not** multiples of the triple 3 4 5.

$$5 \ 12 \ 13$$

$$7 \ 24 \ 25$$

$$9 \ 40 \ 41$$

$$11 \ 60 \ 61$$

Do you notice anything about these triples?

1. **The 2nd two numbers only differ by 1.**
2. **The sum of the 2nd two numbers is equal to the square of the first number.**

a	b	c	a^2	$\frac{a^2}{2}$
3	4	5	9	4.5
5	12	13	25	12.5
7	24	25	49	24.5
9	40	41	81	40.5
11	60	61	121	60.5

Knowing this, form a Pythagorean Triple with 13 being the first number.

We first take the square of 13: $13^2 = 169$

We then divide this square by 2: $\frac{169}{2} = 84.5$

Therefore, the Pythagorean Triple is 13 84 85.

Problem Set

“*” indicates challenge question

- Let a and b be the lengths of the legs of the right triangles below (in cm), and let c be the length of the hypotenuse (in cm). Solve for the missing length. Simplify your answers.
 - $a = 1, b = \sqrt{3}, c = ?$
 - $a = 2, b = 2, c = ?$
 - $a = 6, b = ?, c = 10$
 - $a = ?, b = 24, c = 25$
 - $a = 2, b = 4, c = ?$
- Find the Pythagorean Triple that contains a first number of 17.
- Which of the following is NOT a Pythagorean Triple?
 - 19 180 181
 - 35 612 613
 - 40 76 86
 - 12 35 37
- Which of the following is a Pythagorean Triple?
 - 7 8 11
 - 10 24 25
 - 1 1 2
 - 11 60 61
- If a bird is on the ground, 5 metres away from the base of a tree, and the bird flies 13 metres to the top of the tree, how tall is the tree?
- Denver is in a hot air balloon that has just taken off and is now floating 12 metres above its launching point. Regan is standing on the ground, 16 metres away from the launching point. How far apart are Denver and Regan?

7. If the length of a rectangle is 24m and the length of the diagonal is 26m, what is the width of the rectangle.

8. Solve for the missing lengths.

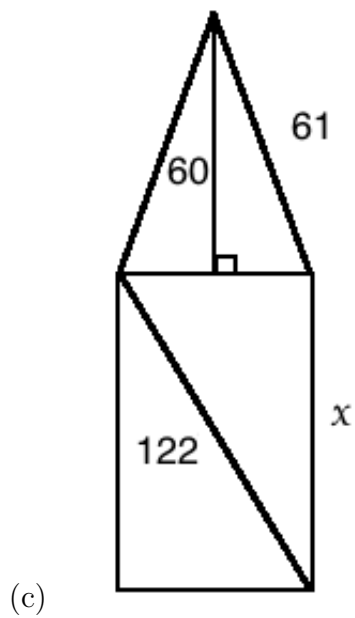
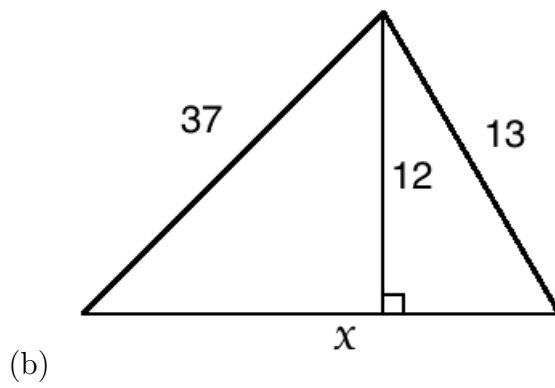
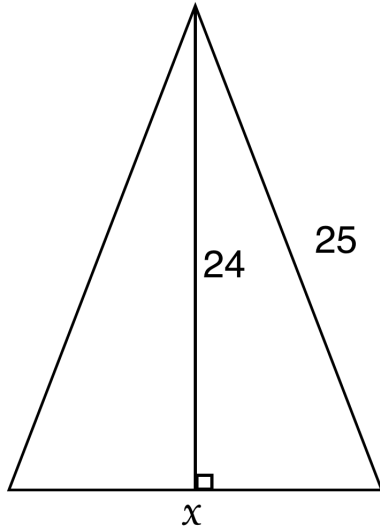

9. Solve for the length of AB

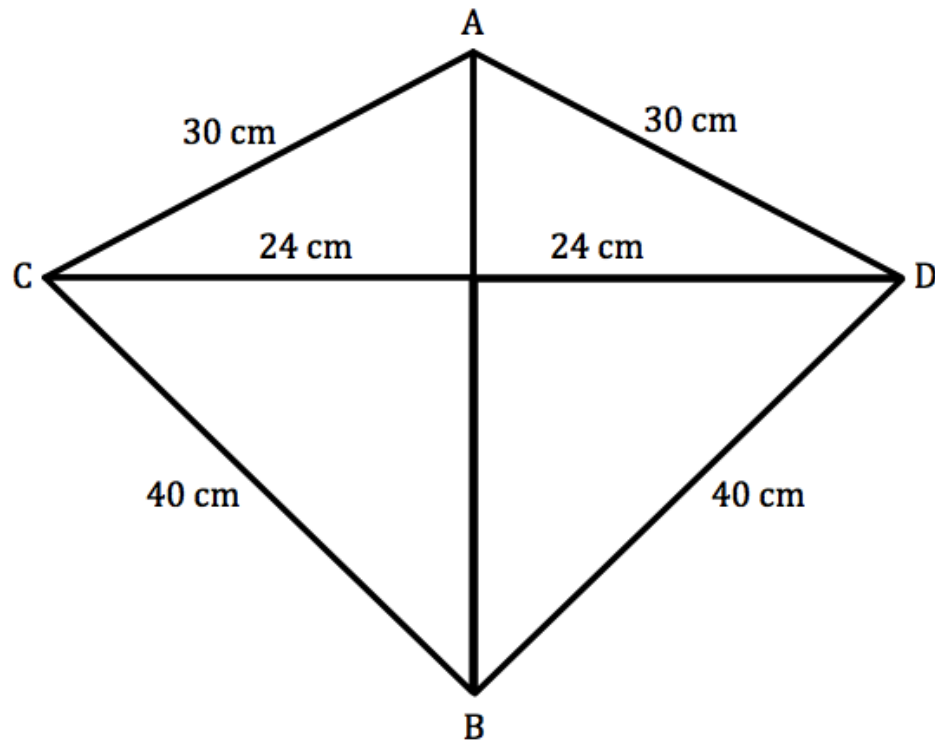

10. Solve for the area of the following shapes:

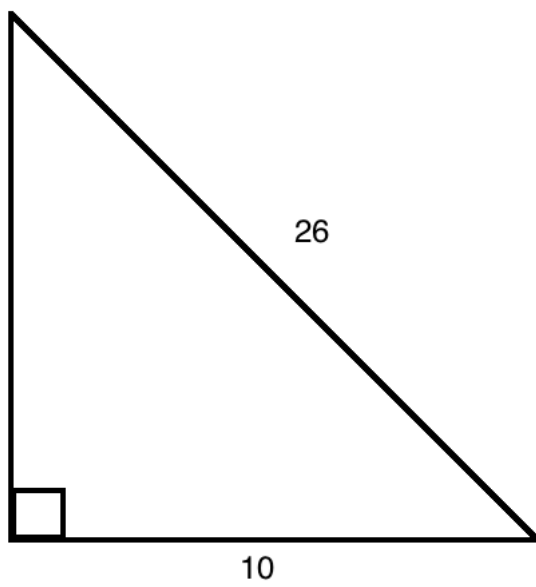

(a)

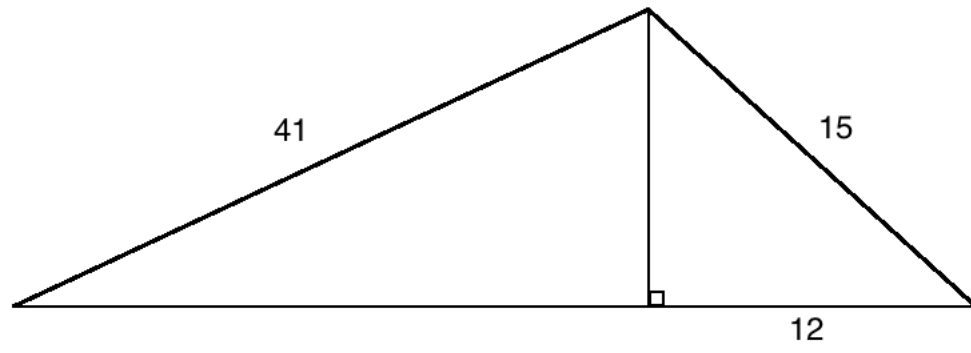

(b)

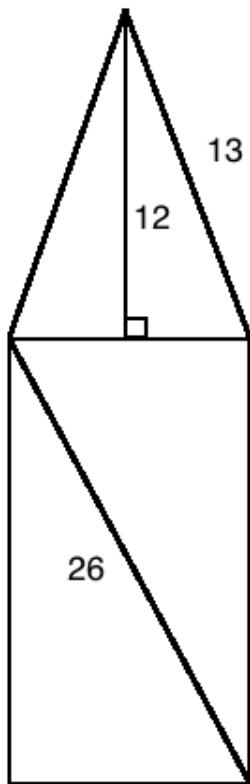

(c)

11. * If the area of of an isosceles triangle is 32cm^2 , and the base and height of the triangle are the same, what are the lengths of the other two sides.
12. * In the proof of the Pythagorean Theorem, use algebra to show that the area of the shaded region of the big square is equal to the area of the shaded region of the two smaller squares.
13. * Given the rectangular prism below, solve for the length of AH.

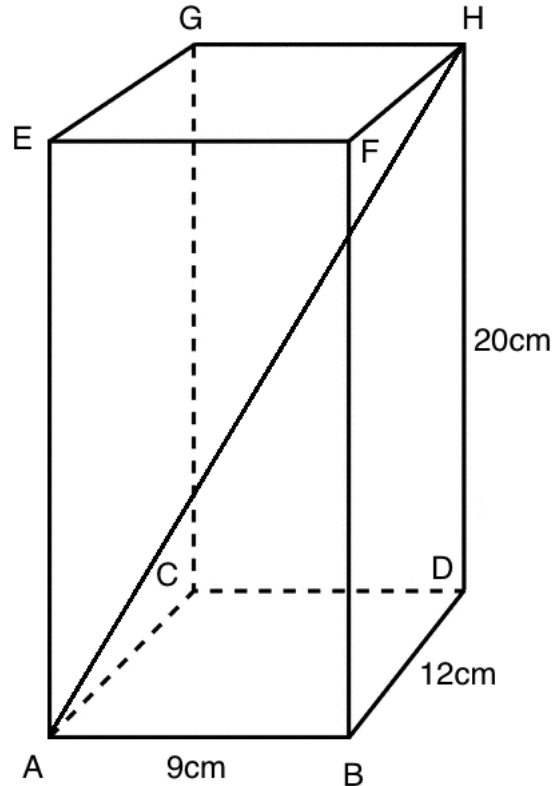

14. * A square-based pyramid has a height of $\sqrt{31}\text{m}$ and a base area of 100m^2 . What is the length of the slant of the pyramid (length from the corner of the base to the top of the pyramid)?
15. * Solve for the area of the trapezoid given the following information (round any calculations to one decimal place).

