

Math Circles: Topology

Amanda Garcia

November 20, 2019

An important concept in mathematics is that of “sameness”: knowing when two (or more things) are the same.

So what does it mean for two things to be the same?

Question What are some ways that things can be the same?

Topology is the study of shapes and of spaces. The notion of “sameness” in topology is called *topological equivalence*; let’s have a look:

Definition. Two figures are *topologically equivalent* if one figure can be transformed into the other by twisting and stretching, but not tearing, cutting, or gluing.

Example Let’s work with a beach ball full of air.

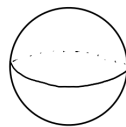

We *can* bend the ball and stretch the ball:

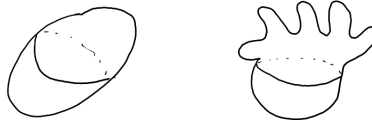

We *cannot* poke holes in the ball, cut the ball, or glue the ball:

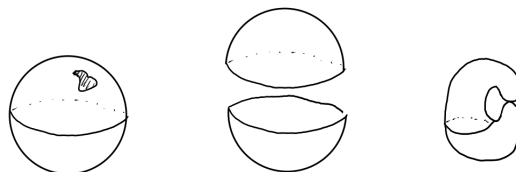

Exercise Determine whether each pair of objects is topologically equivalent or not. Briefly explain your reasoning.

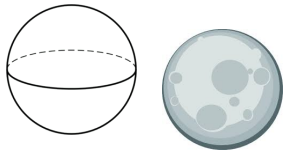

The shell of a sphere and the moon

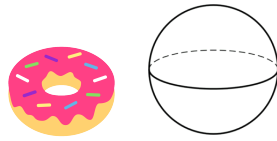

A doughnut and the shell of a sphere

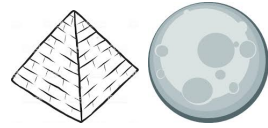

A pyramid and the moon

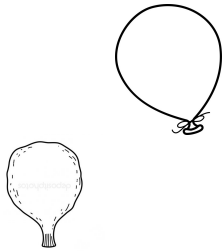

A deflated and an inflated balloon

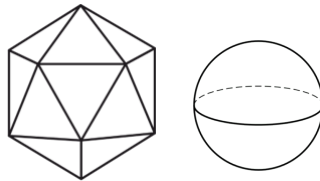

A solid polyhedron and the shell of a sphere



A doughnut and a pyramid



A doughnut and a straw



Shorts and a double doughnut

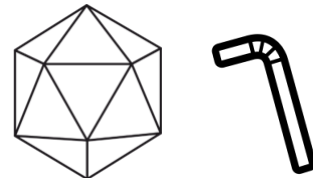

A solid polyhedron and a straw

Exercise Group the objects below by topological equivalence. What do you notice?

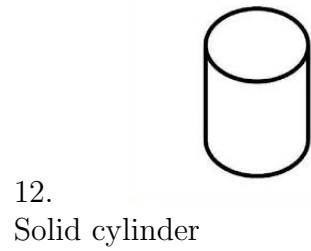
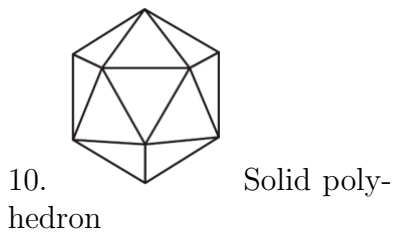
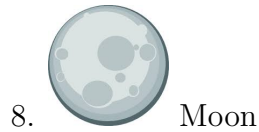
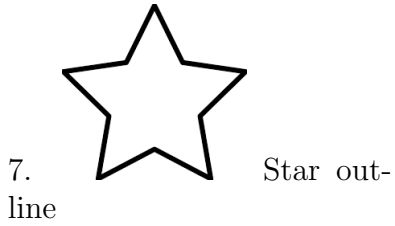
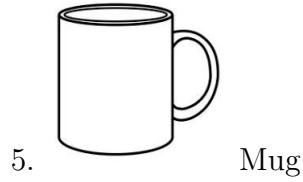
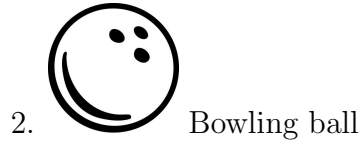
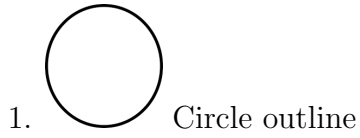

Field Notes

Now that we have an idea of how “sameness” is defined in topology, we’ll spend the rest of our time exploring some common topological spaces.

1. Torus

Maybe you’ve heard of (or played) the game Pac-man before:

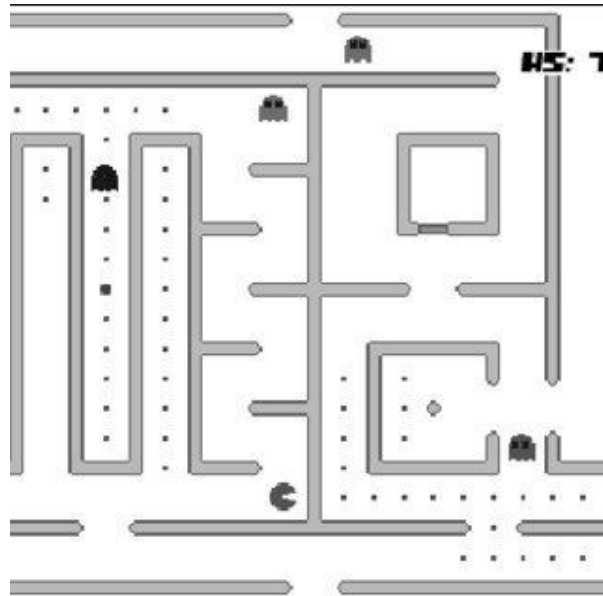

Question What happens when a ghost exits from the top or bottom of the screen?

Question What happens when a ghost exits from the right or left of the screen?

Question If you were given a piece of paper, how could you re-create what happens to the movement of the ghosts in Pac-man?

We can represent the “gluing” of the ends of the Pac-man game with arrows along the sides of the game surface. From now on, we will use a rectangle with arrows on the side to represent this topological object, which we call a *torus*:

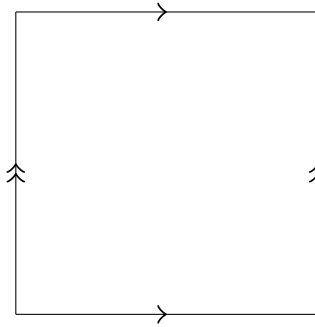

As you can see, if we glue the matching edges to each other, and with a bit of stretching (which is allowed!), we get a torus!

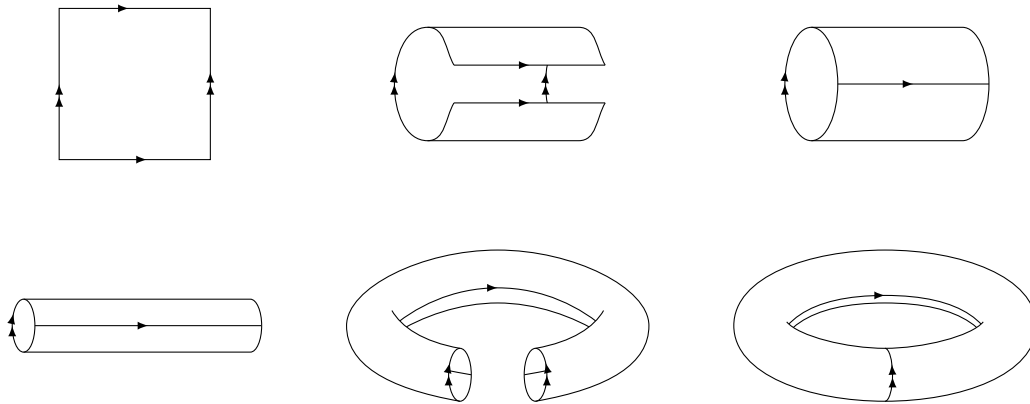

<https://www.youtube.com/watch?v=41UIokTSV3E>

Note We are only considering the torus as a shell and not as a solid object. Think of the torus as an inflatable pool tube!

Now that we have our space, let’s look at how things move along its surface.

Exercise Suppose that you have a pentagon moving along the surface of a torus. Complete the pictures below to illustrate the pentagon’s movements.

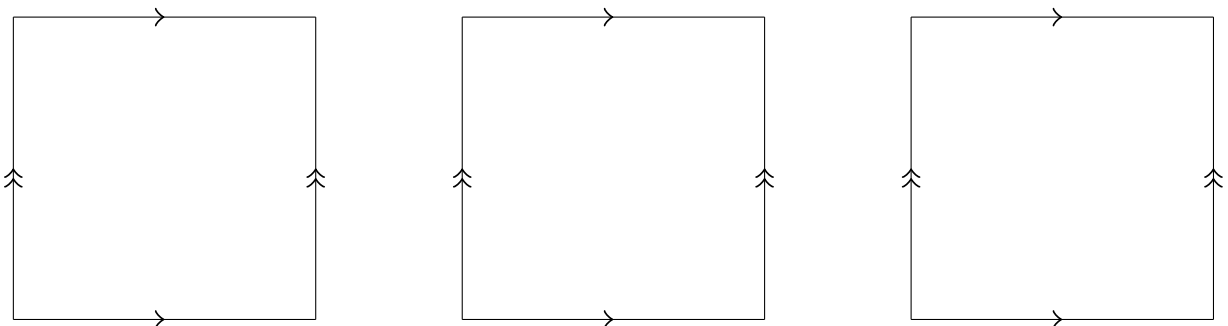

Game Maybe you've played the game tic-tac-toe before: the goal is to make three Xs or Os in a row. Place the winning move for the X player in the games below:

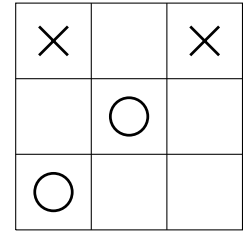
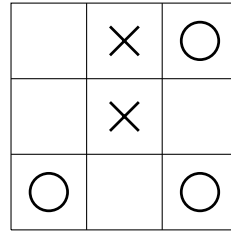
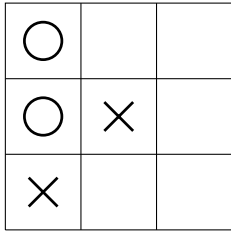

Now, let's add a twist by playing on a torus instead of a regular square. The rules are the same as before, but now there are new ways to win. Here's one new way:

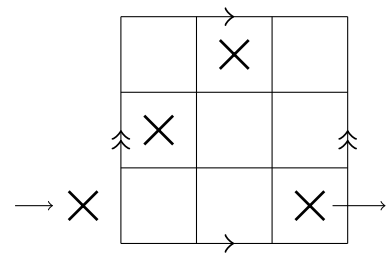
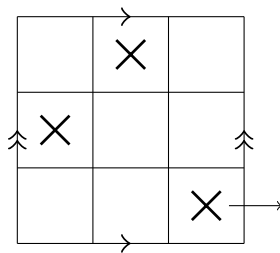
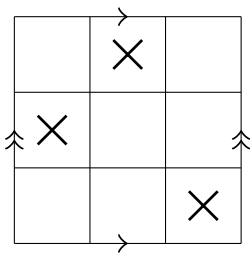

Take a few minutes to play Torus Tic-Tac-Toe with a partner. Try to find more ways to win!

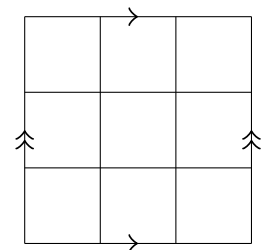
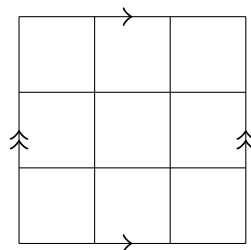
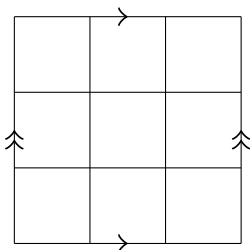
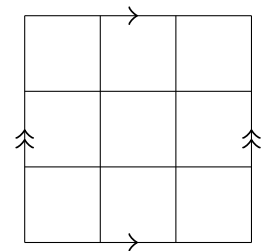
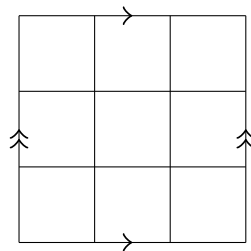
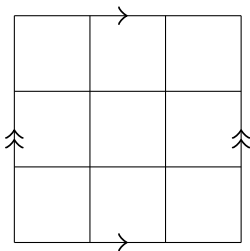
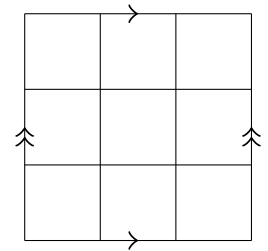
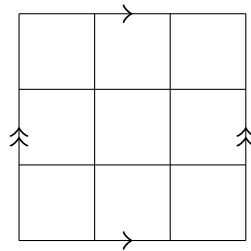
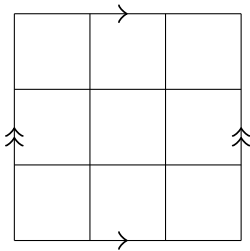

Problem Set I

- Group the following letters by topological equivalence. Remember, you are allowed to stretch and twist, but *cannot* tear, cut, or glue the letters.

l i o j v s

- Choose your name or a favourite word and write it out in block capital letters. Determine which letters in that word are topologically equivalent.

- For each torus and figure pair shown below, draw the missing part of the figure in the correct location of the torus.

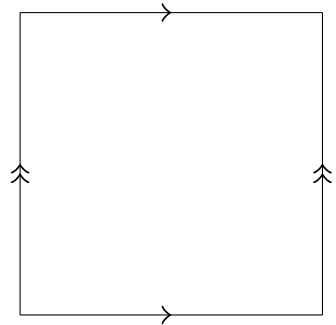
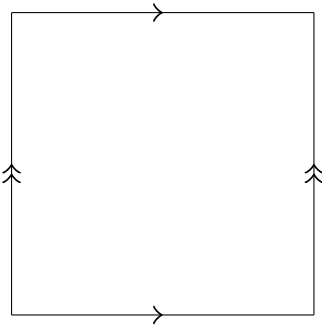
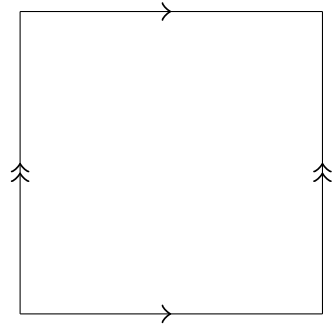
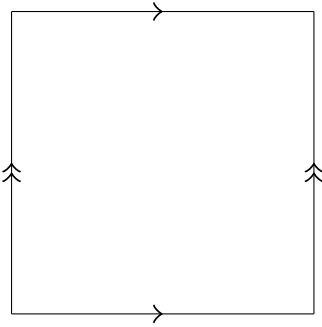

- Find the four new ways to win at Torus Tic-Tac-Toe and illustrate them below.

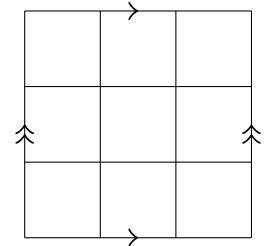
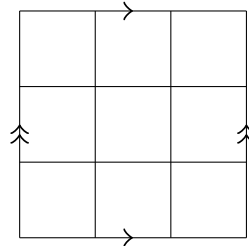
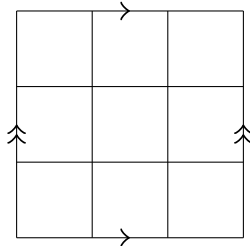
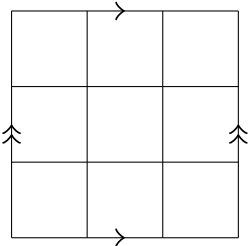

5. Consider the topological space illustrated below, where all of the sides are identified:

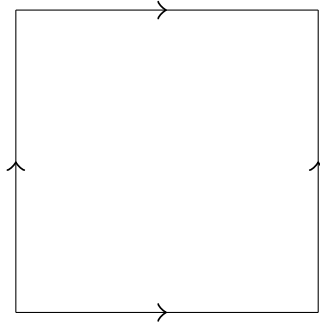

Which space does this correspond to?

6. Consider the topological space illustrated below, where only two of the sides are identified:

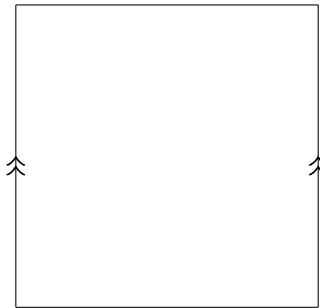

Which space does this correspond to?

References

Some problem set exercises borrowed and/or adapted from Ferron, Nathaniel, " *An Introduction to Topology for the High School Student*" (2017). Masters Essays. 76. <http://collected.jcu.edu/mastersessays/76>